

Flight Cage ASSEMBLY

Instructions online at www.prevuepet.com

CUSTOMER SUPPORT

For assistance or replacement parts, please contact Prevue Pet Products:

PHONE 1 (312) 243-3624

ONLINE www.prevuepet.com

EMAIL customerservice@prevuepet.com

1 PIECES

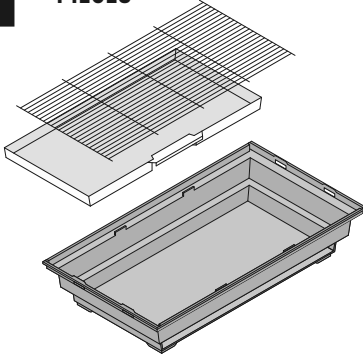

Place the removable grille into the base.

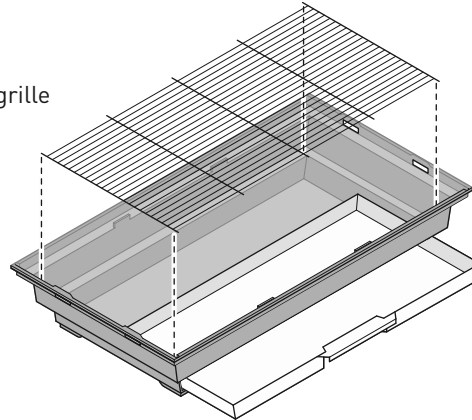

Slide the removable tray into the opening.

2 PIECES

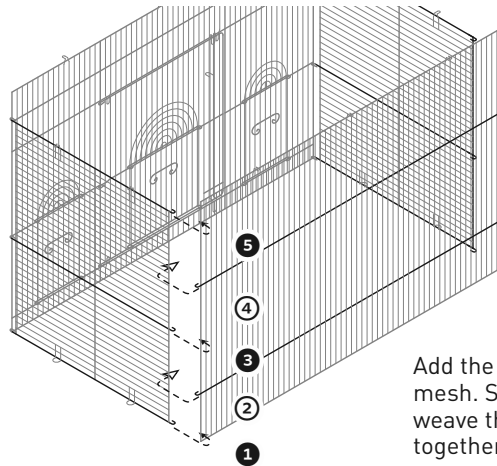
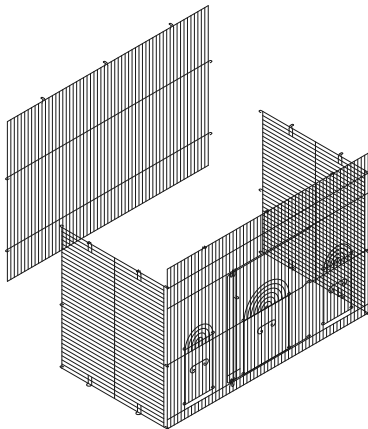

Add the back panel to the 3-panel mesh. Start at the bottom and weave the alternating hooks together up the seam.

Done correctly, the seam will look like this →

Weave the panels together on the remaining seam by the same method.

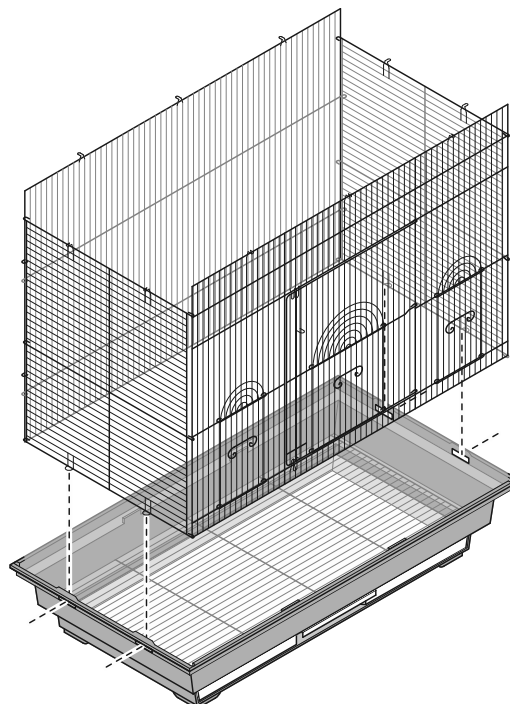
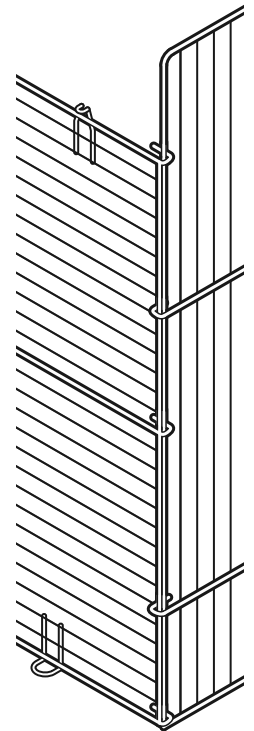

Add the assembled mesh to the base, by inserting the extended loops along the sides into the open slots on the base.

Along the front and back edges, set the mesh between the raised tabs and the rim.

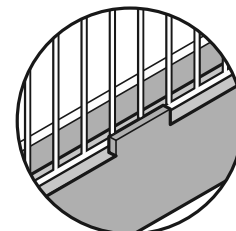

3 PIECES

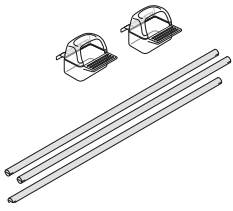

Install the perches on horizontal wires at an equal height.

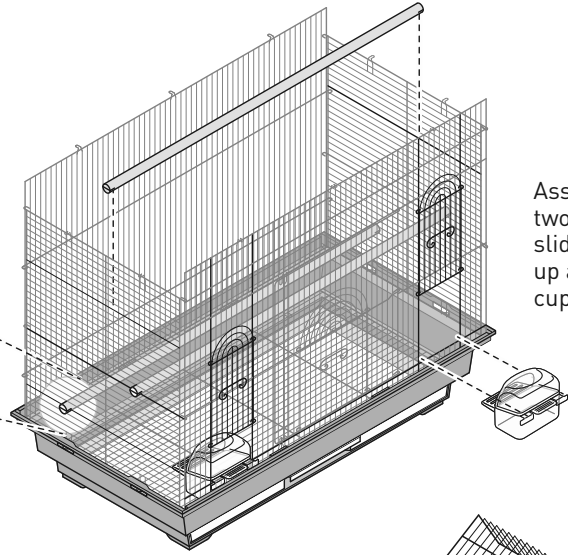
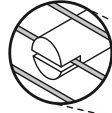

Assemble the two-piece cups, slide the cup doors up and insert the cups into place.

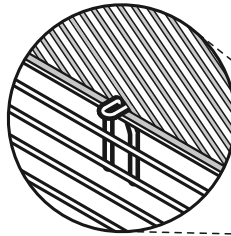
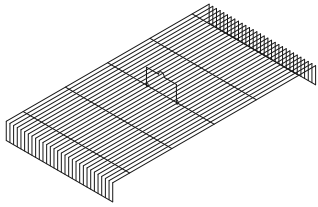

Starting on one end, catch the roof on the looped hooks along the side, then along the front and back panels, and finish with the hooks on the opposite end.

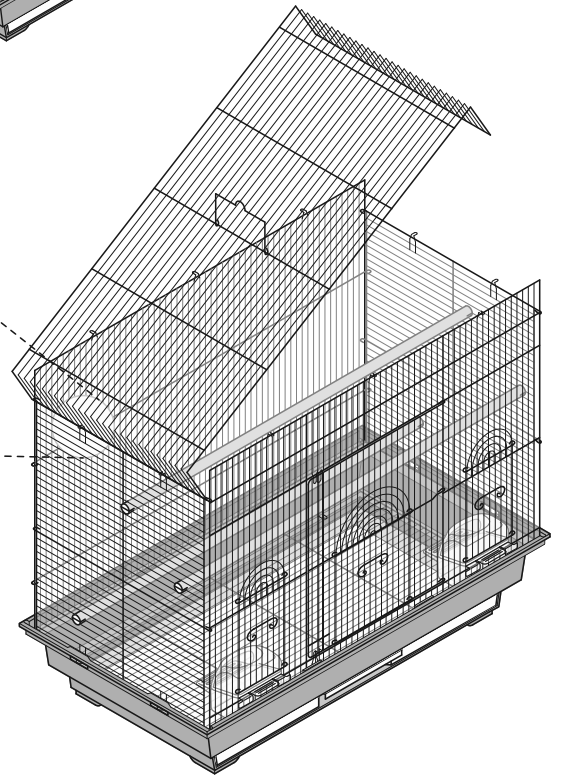

*

CLEANING INSTRUCTIONS

To prolong the life of your new Prevue Pet Products cage, we recommend:

- When cleaning the cage and parts, use a soft cloth or non-abrasive scrub pad (such as Prevue's Cage Saver (#109)).
- Wash all parts with warm water and a mild environmentally friendly, pet-safe soap.
- Rinse thoroughly.
- Hand dry all parts completely with a soft dry cotton cloth before reassembling the cage.
- Do not leave plastic parts in the sun to dry as they may warp.

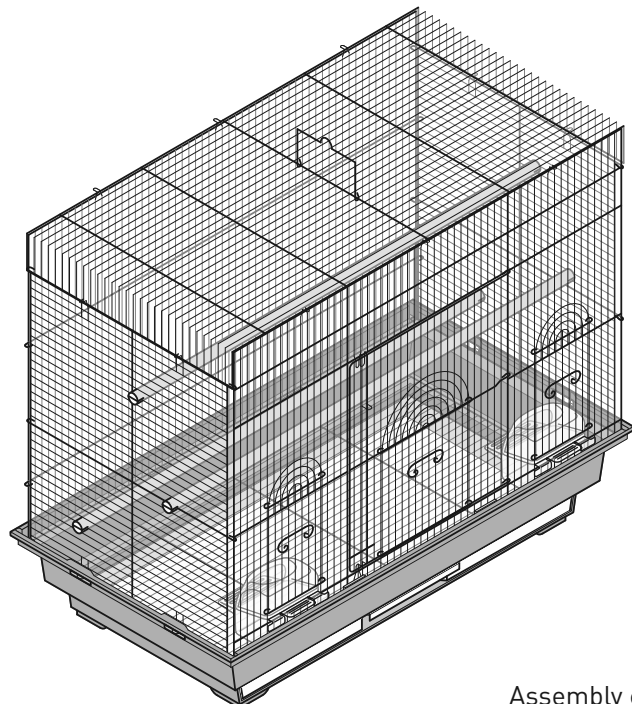

Assembly completed. 