

NO TOOLS NEEDED • For best results, follow Assembly Steps in the order presented.

1 PIECES

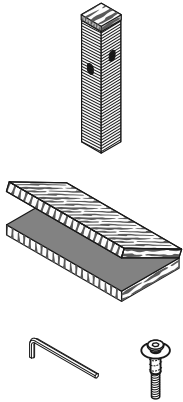

Unfold the base.
Tighten the screw
through the base and
into the post.
The metal sleeve on
the screw will implant
itself into the wood.

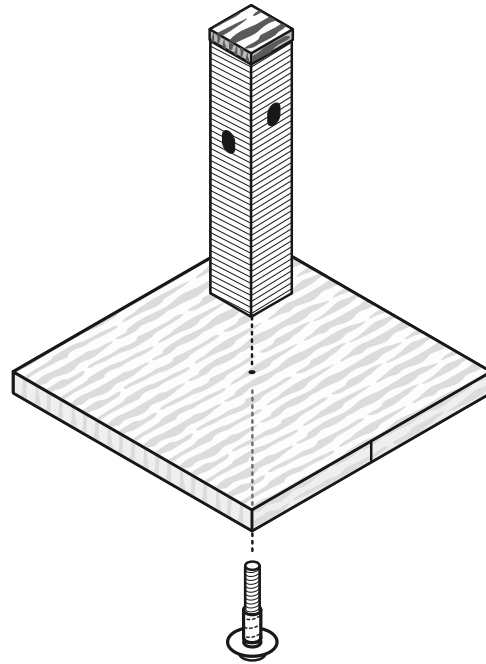

2 PIECES

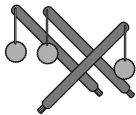

For each bounce 'n spring arm :
① Insert the screw post into the
threaded hole at an angle.
② Screw securely into place.

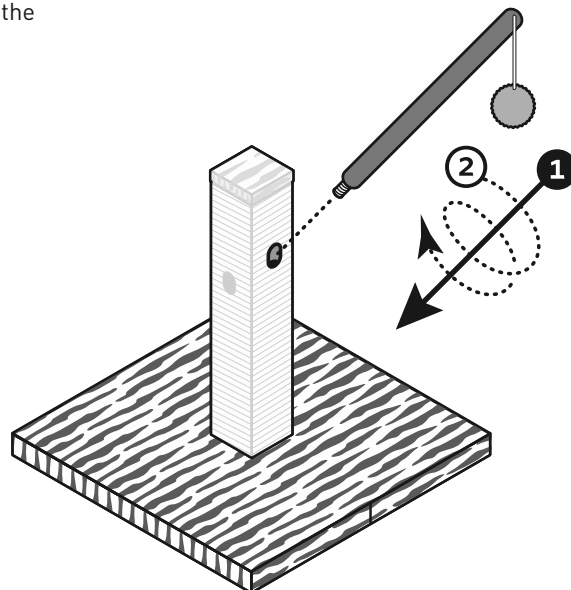

Assembly completed. ■