

KeetTiel Cage ASSEMBLY

Instructions online at www.prevuepet.com

CUSTOMER SUPPORT

For assistance or replacement parts, please contact Prevue Pet Products:

PHONE 1 (312) 243-3624
ONLINE www.prevuepet.com
EMAIL customerservice@prevuepet.com

1 PIECES

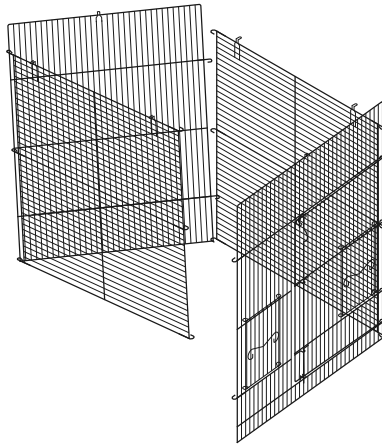
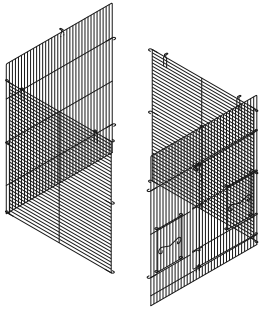

Attach the **back panel** to the **right-side panel**:
Start at the bottom corner and weave the alternating hooked wires of the two panels together, up the seam, to the top.

Repeat the method with the front seam (**left-side panel** to front panel).

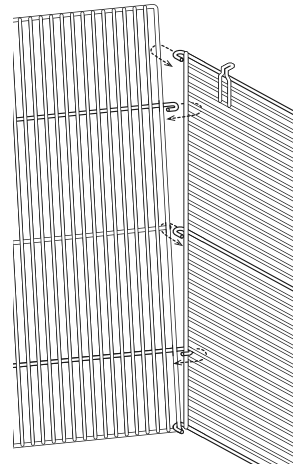

2 PIECES

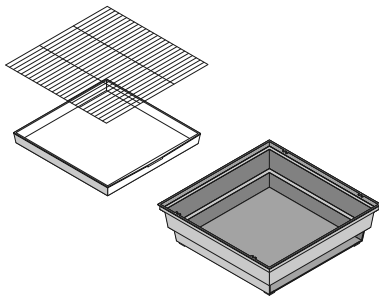

Place the **grille** down into the base and slide the **tray** in from the front.

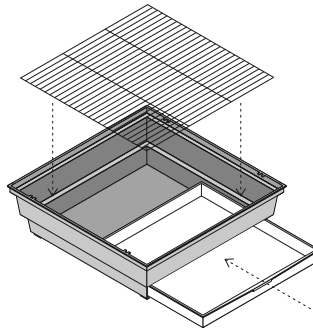

Set the assembled cage body into the **base**.

Catch the side panels under the tabs along the rim of the base.

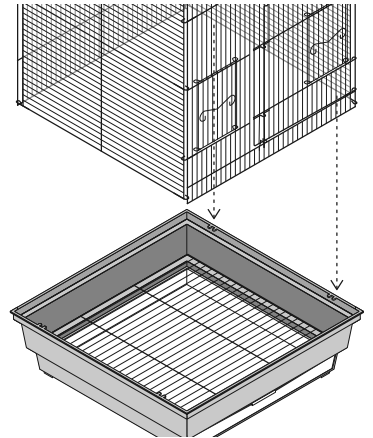
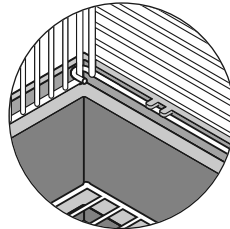

3 PIECES

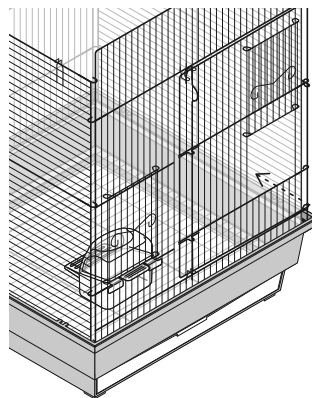
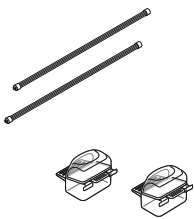

Assemble the **two-piece cups**.
Slide the cup doors up and insert cups.

Place **perches** on horizontal wires at a level height.

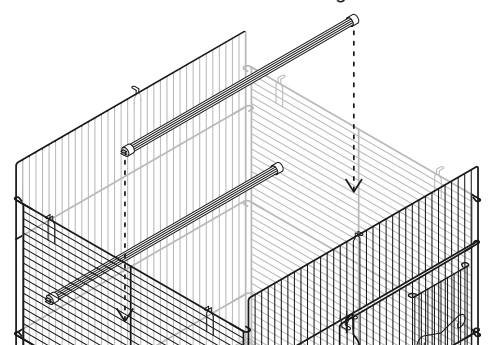

4 PIECES

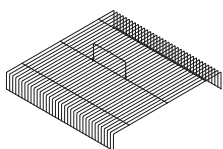

Attach the **roof**.
Start on one side and catch the bottom horizontal wire under the loops on the side panel.
Softly bend the roof mesh to catch the roof line onto the front and back panel loops.
Finish by catching the roof onto the opposite side loops.

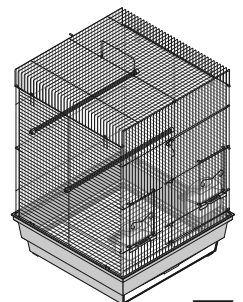
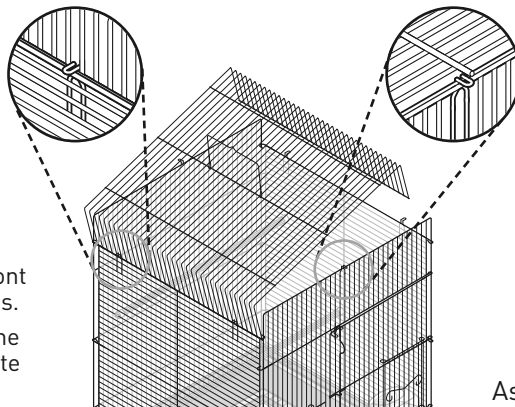

Assembly completed. ■