

TOOL: Flathead or Phillips-head screwdriver • For best results, follow the Assembly Steps in the order presented.

**1** PIECES

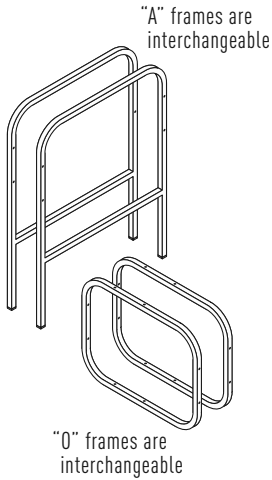

**\*** IMPORTANT: Depending on the orientation of the side "O" frames, this stand will work for either 18 × 18 bases or 18 × 14 bases:

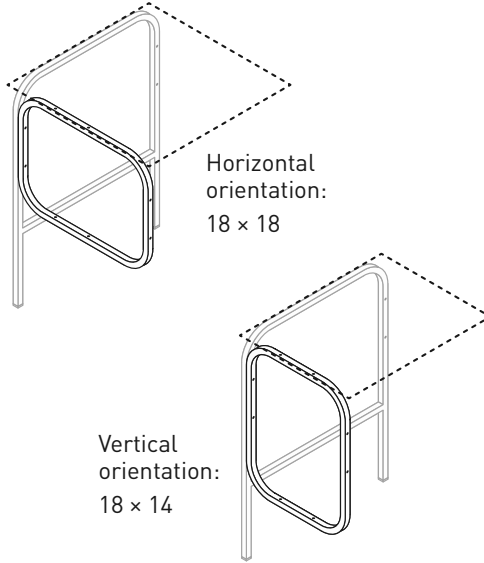

Attach the **side panel "O" frames** to the **front and back "A" frames**. Attach the wing nuts from the inside of the frames. Leave the screw/wing nut connections a little loose at this stage.

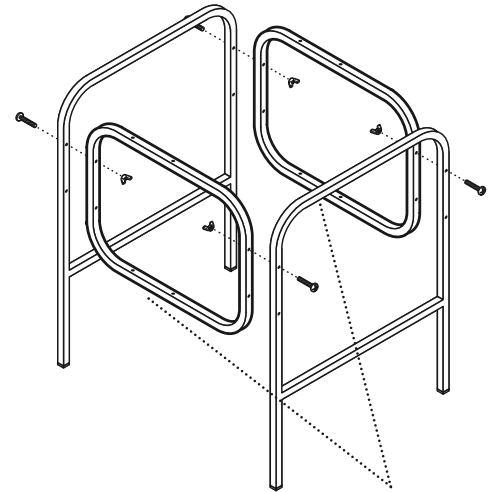

For the Horizontal (18×18) orientation, make sure the off-center holes for the shelf are parallel/at the same end.

**2** PIECES

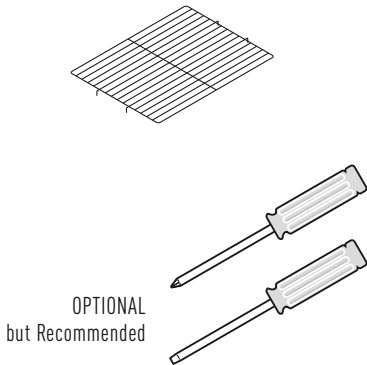

Insert the extended wires of the **shelf** into the holes on the side panel "O" frames.

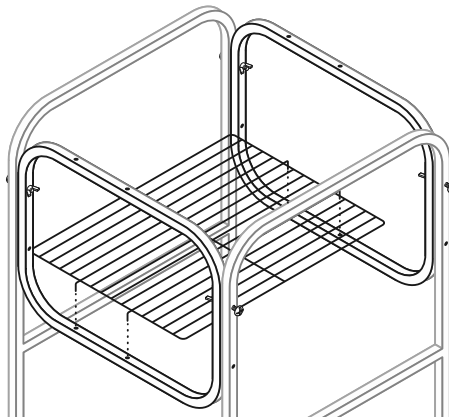

Finish attaching the frames together with the remaining screw/wing nuts. Now, tighten all connections snugly. A flathead or philips screwdriver can be used to tighten the screws if preferred.

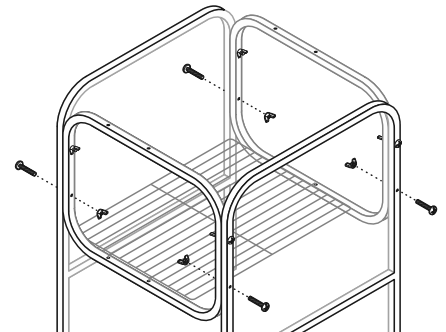

**3** PIECES

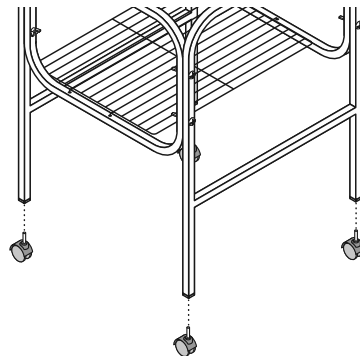

With the stand upright, insert the **casters** into the "A" frame legs.

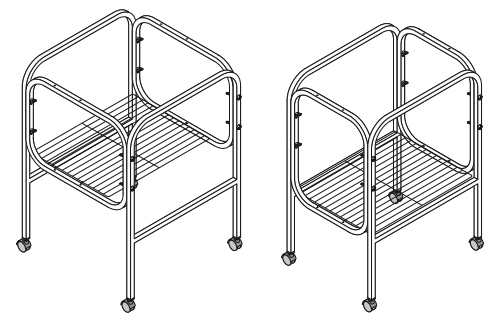

Assembled for 18 × 18 base

Assembled for 18 × 14 base

Assembly completed.